

Lessons learned from one of New Zealand's most challenging civil engineering projects: rebuilding the earthquake damaged pipes, roads, bridges and retaining walls in the city of Christchurch 2011 - 2016.

## DG064 Design of an Automated Flushing Siphon System

**Story:** Design of an Automated Flushing Siphon System

**Theme:** Design

---

A guideline to inform designers on the design of an Automated Flushing Siphon System as a means to reduce the frequency of blockages on the wastewater network caused by pipe dips and flat grades.

This document has been provided as an example of a tool that might be useful for other organisations undertaking complex disaster recovery or infrastructure rebuild programmes.

For more information about this document, visit [www.scirtlearninglegacy.org.nz](http://www.scirtlearninglegacy.org.nz)



This work is licensed under a [Creative Commons Attribution 3.0 New Zealand License](https://creativecommons.org/licenses/by/3.0/nz/).

The authors, and Stronger Christchurch Infrastructure Rebuild Team (SCIRT) have taken all reasonable care to ensure the accuracy of the information supplied in this legacy document. However, neither the authors nor SCIRT, warrant that the information contained in this legacy document will be complete or free of errors or inaccuracies. By using this legacy document you accept all liability arising from your use of it. Neither the authors nor SCIRT, will be liable for any loss or damage suffered by any person arising from the use of this legacy document, however caused.

## DESIGN GUIDELINE

Number: 064  
Design Group: WW  
Revision: 2  
Original: 27/06/14

- |  |                                     |   |
|--|-------------------------------------|---|
| <input checked="" type="checkbox"/> Wastewater | <input type="checkbox"/> Stormwater | <input type="checkbox"/> Geotechnical       |
| <input type="checkbox"/> Structures            | <input type="checkbox"/> Roading    | <input type="checkbox"/> Water Reticulation |

**Subject: Design of an Automated Flushing Siphon System**

Original: John Kindness

Approved:

Updated by: John Walter (31Oct16)

Keywords: Automated Flush Tank, Flushing Siphon Chamber, Wastewater, Grade Dispensation, Flushing Siphon Device, Jetting Alternative

## 1 Purpose of Guideline

To provide guidance on the design of an Automated Flushing Siphon System as a means to reduce the frequency of blockages on the wastewater network caused by pipe dips and flat grades.

## 2 Background

The Christchurch wastewater network consists of pipes laid at typically shallow grades in the flat regions, and pipes laid at steeper grades in the Port Hills. Historically these shallow grades have led to blockages forming in areas where there are insufficient flows to maintain a free flowing network. These blockages have resulted in problems on private property from blowbacks, the inability to flush toilets, and wastewater overflowing onto private property.

To reduce this risk, Council has installed over 1600 flush tanks and flush manholes around the city. These chambers were concrete structures, usually located at the head of wastewater pipelines, which contained either a flap valve or a plug to isolate them from the rest of the network. A water supply connection to the chambers was separated from the rest of the water supply system by an air gap separator (AGS).

The flush tanks and flush manholes were/are operated manually about 5 weekly by a member of the Council's Operations Team, once the chamber was full, by opening the flap valve or pulling out the plug and allowing the stored water to flow down the wastewater pipeline. They then followed the flush wave downstream to ensure that the pipeline was flowing freely and dealt with any sediment accumulation or blockage issues not resolved by the passing of the flushing wave. Operation of these chambers was part of the Council's proactive maintenance regime; the flushing would be carried out at set time intervals.

Over the years prior to the 2010 and 2011 earthquakes, operation of 1000 of the flush tanks and flush manholes was discontinued as part of a water conservation measure, with only some of the maintenance cycles in the blockage-prone areas being maintained, most notably around the malls to mitigate the build-up of fat deposits within the wastewater network.

Council maintains a list of all the flush tanks and flush manholes and recently had them surveyed (in 2011/2012) for operability. This survey revealed that a lot of them were in good condition whilst others had problems such as the AGS no longer working or the chamber having become no longer watertight.

The 2010 and 2011 earthquakes affected soil properties and caused ground movement. This created dips along wastewater pipes and reduced some pipe grades. Across the city there are now pipes with significant dips, and grades below pre-IDS grade requirements (refer to Appendix A). These pipes have an increased risk of blockage, especially where they suffer from low or infrequent flows.

Whilst dips can generally be repaired using a short section of new pipe, restoring flat graded pipes to at least pre-IDS grades can require the relay of hundreds of metres of new pipe and possibly the installation of a lift station. To avoid this extensive relay of pipes, which structurally may have many years of service left, it may be an option to install flushing siphon devices at points around the wastewater network to provide frequent flushing of flat pipes thus minimising the risk of blockage and odour emission. The majority of dips within the flushing zone of influence might therefore not require repair.

A Scope and Standards Paper is required for all new Flushing Siphon Chambers.

### 3 Terminology

Terminology used in this guide for the various flushing system components are:

- Flushing Siphon System – the complete system including all of the components below
- Flushing Siphon – the flushing siphon mechanical device
- Flushing Siphon Chamber – contains the flushing siphon
- Flush Reservoir – additional water storage volume separate from the siphon chamber

## 4 Design Requirements

### 4.1 Flushing Siphon Device

The Steinhardt HydroFlush device is used by SCIRT. It is available in a variety of sizes dependent upon the required flushing rate. (Refer to Appendix B for HydroFlush Device Data). The distributor of the devices in New Zealand is Masons Mechanical and Environmental Engineers in Auckland.

---

<sup>1</sup> These grades were never a Christchurch Drainage Board or Christchurch City Council design standard and were termed 'Pre-IDS grades' within Council's 'Infrastructure Recovery Technical Standards and Guidelines' (IRTSG). They originated from a list, produced in 2011, of the flattest known pre-quake pipe grades across Christchurch. In all cases these pipes included a flush tank upstream and required occasional manual cleaning.



**Figure 1: Steinhardt HydroFlush Device without outer casing**



**Figure 3: Steinhardt HydroFlush Device installed at Marley View Street**

The device consists of an inner and outer pipe located within a watertight chamber (the Flushing Siphon Chamber) and it operates in the following sequence (Refer to Appendix C for diagrams):

1. The chamber is filled at a constant rate from a water supply source
2. Once the water level reaches the top of the inner pipe the siphon process is initiated
3. The water is siphoned out of the chamber and flushed down the wastewater pipeline
4. The water level in the chamber reaches the bottom of the outer pipe and drawn-in air breaks the siphon process
5. The remaining water within the outer pipe flushes back into the chamber
6. The water level starts to rise in the chamber again (the flow from the water supply does not stop)

The size of device and water supply fill rate should be selected to ensure that the siphon operates a minimum of once a week to limit sediment build up and the opportunity for inter-particle cohesion to develop.

## 4.2 Installation Types

There are three main installation configurations for a Flushing Siphon Chamber (a structure that contains a Flushing Siphon device). These are:

- Top of line
- Inline
- Offline

### Top of line

This is where the Flushing Siphon device can be installed at the head of a pipeline (similar to a flush tank). The device can either be installed in an existing Flush Tank, an existing manhole or a new manhole. This is the simplest Flushing Siphon Chamber to design and construct as there is a smooth hydraulic transition into the pipeline and there are no existing flows to bypass. Refer to Top of Line Flushing Siphon Chamber (Template) drawing in Appendix D.

### Inline

This is where the Flushing Siphon device needs to be installed part way along a pipeline. The device is supported on a watertight base mounted in the Flushing Siphon Chamber above the pipe to be flushed. Although the device can be retrofitted into an existing manhole, generally the required storage volume will exceed what is available. A new larger manhole is therefore usually required. This is a more complex Flushing Siphon Chamber to construct as it requires bypassing existing flows and multiple pipe connections. Refer to Inline Flushing Siphon Chamber template drawing in Appendix D.

### Offline

This is where the Flushing Siphon device needs to be installed part way along a pipeline, but can be installed offline. It is likely to only be used where there is an existing offline structure that can be utilised. The flushing siphon device is retrofitted into the offline structure which removes the requirement to divert wastewater flows. To prevent flow interference the angle of connection into the main pipeline should be no greater than 30° (from parallel). Where this cannot be achieved the storage volume should be increased by between 10% - 30%. Refer to Offline Flushing Siphon Chamber (Template) drawing in Appendix D.

## 4.3 Additional Design Considerations

It is important to ensure that there are no lateral connections into the structure used as a Flushing Siphon Chamber; if there are then they will need to be diverted into the upstream or downstream pipe.

Where there are manholes along the pipeline to be flushed, these need to be benched to the top of the incoming or outgoing pipe (whichever is greater) to avoid the flush dissipating into the manhole.

Flushing Siphon Chambers should only be used where the wastewater network will not surcharge to the extent that it drowns out the flushing siphon device.

Where there is a grass berm between the sealed footpath and the road, the footpath formation is to be widened as required to maintain a 1.5 m minimum width around the water supply boxes.

## 4.4 Design Steps

The assessment criteria for identifying the potential for a Flushing Siphon Chamber is shown in Figure 3.

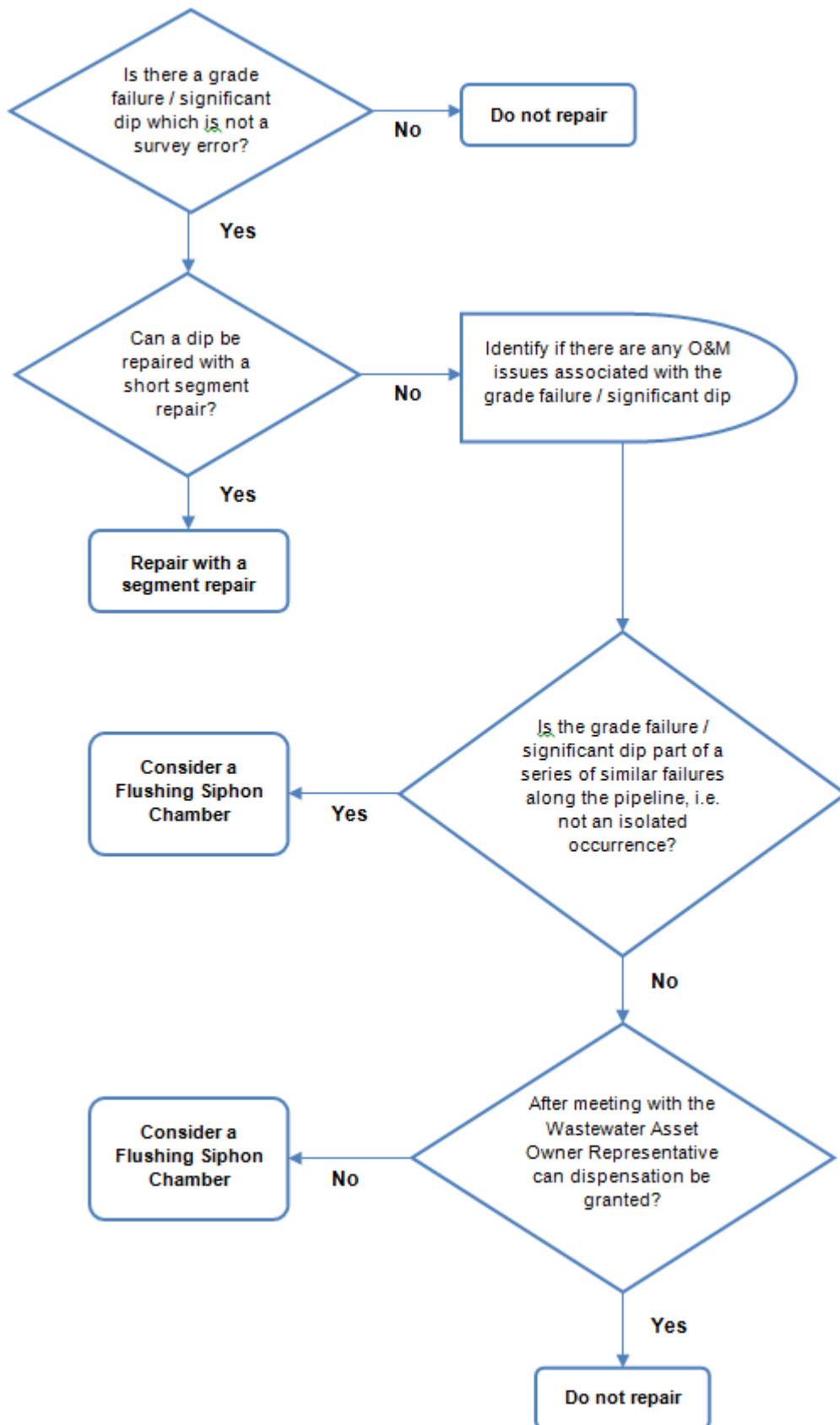

Figure 4: Flushing Siphon Chamber Assessment Criteria

The design of a Flushing Siphon System should follow the following steps:

1. If there is an existing flush tank or structure that can be modified, request a survey of the structure to obtain: ground levels, internal width, internal height, internal length, outgoing pipe diameter and level, internal arrangement, and photographs.
2. Use the survey results to determine what size flushing siphon device can be retrofitted (cylinder diameter and height) (refer to Top of Line Flushing Siphon Chamber (Template) and Offline Flushing Siphon Chamber (Template) drawings in Appendix D) and the available flushing volume.
3. If there is no existing structure, use the pipe invert levels at the proposed Flushing Siphon Chamber location to determine what size of flushing siphon device can be used (refer to Inline Flushing Siphon Chamber (Template) drawing in Appendix D) and the available flushing volume.
4. The design of flushing siphon device and flush volume are the responsibility of the supplier (see below). Email the following information to the supplier so that they can identify the required flushing volume: pipe asset id, diameter, length, upstream IL, downstream IL, grade and identification of any downstream bends (i.e. changes of direction at manholes) for all pipes that require flushing (i.e. if the 1<sup>st</sup> and 4<sup>th</sup> pipes require flushing, provide details for the 1<sup>st</sup>, 2<sup>nd</sup>, 3<sup>rd</sup> and 4<sup>th</sup> pipes).
5. Compare the required flushing volume against the available flushing volume.
6. If there is insufficient volume available in the existing structure a new structure will be needed.
7. Consider if any modifications are required to the existing network (i.e. does a section of pipe require relaying in order to install the Flushing Siphon Chamber to a sufficient depth to achieve the required flushing volume).
8. If the required flushing volume cannot be provided, liaise with the Wastewater Asset Owner Representative regarding possible dispensation or re-design.
9. Prepare a Scope and Standards Paper for the Flushing Siphon System.
10. Use the drawing templates to produce drawings.
11. Consider the constructability of the Flushing Siphon Chamber, e.g. where retrofitting into an existing structure, does the entire roof slab require removal to enable the structure to be safely modified?
12. Consider the health and safety implications of the Flushing Siphon Chamber, i.e. is it in the middle of a road, will there be confined spaces entry required, etc.
13. Email the finished drawings to Geoff Truscott ([Geoff@masons.co.nz](mailto:Geoff@masons.co.nz)) at Masons Mechanical and Environmental Engineers.
14. Incorporate any feedback from Masons into the design and modify the drawings, report and bill of quantities as required

#### 4.5 Comparison with alternative Methods

The alternatives to installing a new Flushing Siphon System are to either manually operate existing flush tanks (that are not always in the required location) or to proactively jet the pipes that have low grades and/or significant dips as part of a maintenance cycle, or reactively when a blockage or odour issue is reported. The most appropriate method will vary and will depend upon the situation. Refer to Table 1 for comparable costs.



**Table 1: Approximate comparable Costs between cleansing Methods**

	<b>Flushing Siphon Chamber</b>	<b>Flush Tank</b>	<b>Proactive Jetting</b>	<b>Reactive Jetting</b>
<b>Initial Construction Costs</b>	\$7,000 +	\$0 (existing)	\$0	\$0
<b>Job scoping</b>	\$50 (yearly operational check)	\$100 (includes Operations visit)	\$80 (per operation)	\$80 (per operation)
<b>Traffic Management (per operation)</b>	\$0	\$150 (low traffic roads) \$300 (medium traffic roads) \$600 (high traffic loads)	\$150 (low traffic roads) \$300 (medium traffic roads) \$600 (high traffic loads)	\$150 (low traffic roads) \$300 (medium traffic roads) \$600 (high traffic loads)
<b>Offsite disposal (per operation)</b>	\$0	\$0	\$150 - \$300	\$150 - \$300
<b>Fixed Maintenance Costs</b>	\$50 (yearly)	\$250 - \$700 (per operation)	\$380 - \$980 (per operation)	\$380 - \$980 (per operation)
<b>Variable Maintenance Costs (double if additional work and heavy jetting required)</b>	\$0	\$0	\$8/m (jetting)	\$17/m (jetting)
<b>Renewal Costs</b>	\$5000 (to replace the flushing device after approx. 20 years)	\$0	Cost to replace pipeline damaged by jetting (year of renewal dependent upon material and existing damage)	Cost to replace pipeline damaged by jetting (year of renewal dependent upon material and existing damage)

Below are some situations where each of the methods could be utilised.

**A Flushing Siphon Chamber can be utilised when:**

- Several pipes, with poor grades or dips, are adjacent to or close to each other
- The flush reservoir and pipes are in locations difficult to access such as busy roads or private property
- An existing flush tank or manhole can be utilised
- The pipes are fragile or in poor condition
- An existing flush tank has insufficient volume
- Capital expenditure is preferred to operational expenditure

**An Existing Flush Tank can be utilised when:**

- Several pipes, with poor grades or dips, are adjacent to or close to each other
- There is already a flush tank in operational condition at the required location
- The pipes are in locations easy to access (such as berms)
- The pipes are fragile or in poor condition

**Proactive or Reactive Jetting can be utilised when:**

- Several pipes, with poor grades or dips are far away from each other
- The pipes and manholes are easily accessible
- There is no existing flush tank or manhole that can be utilised
- The pipes are undamaged

## 5 System Commissioning

Commissioning of the Flushing Siphon System should include the following:

1. A static leakage test of the Flushing Siphon Chamber by plugging the outlet then filling the chamber with clean water to the top of the access riser. Around the outside of the chamber there should be no visible leaks and the water loss rate as determined by the fall in water level should be no more than the prescribed allowable leakage rate.

The allowable tank leakage rate measured over 24 hours = Flushing Volume / 600

This can be measured as the drawdown within the access riser after initially filling to the top of the riser (or access throat).

Example:

For a 600 diameter circular riser, plan area = 0.28 m<sup>2</sup> for which 1 mm of rise equates to 0.28 L.

For a 2400 litre flushing volume the allowable leakage rate = 2400/600 = 4.0 L per 24 hrs.

Water level fall rate within the riser = 4.0(L) / 0.28(L/mm) = 14 mm per 24 hours

2. Test that the water supply flow rate via the restrictor is as stated on the drawings.
3. Fast fill the chamber to near trigger level, then slow fill until triggering occurs and observe and record that flushing from the chamber and downstream occurs as expected.

## 6 Operation and Maintenance Manual

The Operation and Maintenance Manual should include:

- The Flushing System component descriptions
- The Flushing System functional description
- A list of the required operational checks

Append:

- The flushing siphon manufacturer's Operation and Maintenance Manual
- A photo of the flushing siphon
- The as built drawings

Operational checks should be undertaken monthly for six months then at least annually as follows:

- Record the flow meter reading.
- Calculate the daily water usage over the period.
- Compare water usage with the expected design usage (average litres/day).
- If water usage is high or low: clean or replace the flow restrictor. Also withdraw the flushing siphon device and inspect the components for damage or corrosion as per the manufacturer's Operation and Maintenance Manual.

Check the chamber water tightness annually for those chambers with a flushing interval of 5 days or more.

## Appendix A Shallow Pipe Grades

**Table 2: Pre-IDS Wastewater Pipe Grades**

Pipe DN (mm)	Grade (1 in ...)	Grade (%)
150	450	0.22
175	600	0.17
225	700	0.14
300	800	0.13
>300	Discuss with Asset Owner Representative	Discuss with Asset Owner Representative

## Appendix B Steinhardt HydroFlush Device Data

Table 3: Steinhardt HydroFlush Device Data

Type	Inner Pipe DN (mm)	Outer Pipe DN (mm)	Height (mm)	Average Flow (l/s)	Max Flow (l/s)	Outgoing pipe DN (mm)
<b>70/200/400</b>	70	200	400	5	7	< 200
<b>100/250/400</b>	100	250	400	13	17	200-300
<b>150/350/400</b>	150	350	400	24	30	250-350
<b>200/400/400</b>	200	400	400	40	50	300-400
<b>250/500/400</b>	250	500	400	58	76	350-500
<b>100/250/600</b>	100	250	600	14	18	200-300
<b>150/350/600</b>	150	350	600	25	31	250-350
<b>200/400/600</b>	200	400	600	42	53	300-400
<b>250/500/600</b>	250	500	600	60	72	350-500
<b>300/600/600</b>	300	600	600	68	85	400-600
<b>100/250/800</b>	100	250	800	15	19	200-300
<b>150/350/800</b>	150	350	800	26	32	250-350
<b>200/400/800</b>	200	400	800	44	57	300-400
<b>250/500/800</b>	250	500	800	60	80	350-500
<b>300/600/800</b>	300	600	800	68	90	400-600
<b>150/350/1000</b>	150	350	1000	27	33	250-350
<b>200/400/1000</b>	200	400	1000	45	58	300-400
<b>250/500/1000</b>	250	500	1000	60	80	350-500
<b>300/600/1000</b>	300	600	1000	68	91	400-600
<b>150/350/1200</b>	150	350	1200	28	34	250-350
<b>200/400/1200</b>	200	400	1200	46	59	300-400
<b>250/500/1200</b>	250	500	1200	60	80	350-500
<b>300/600/1200</b>	300	600	1200	68	93	400-600

Appendix C Operation of Flushing Siphon Device

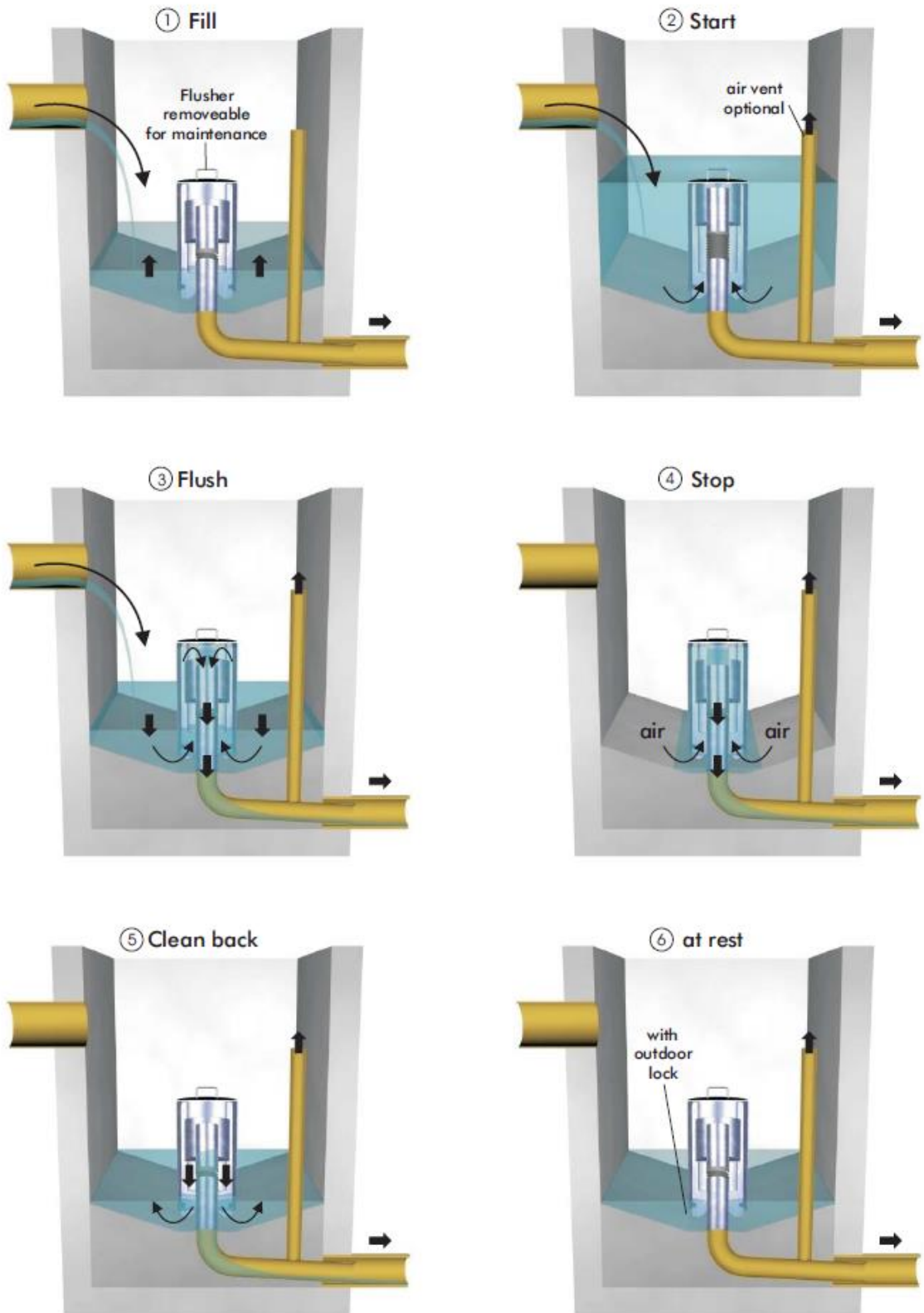
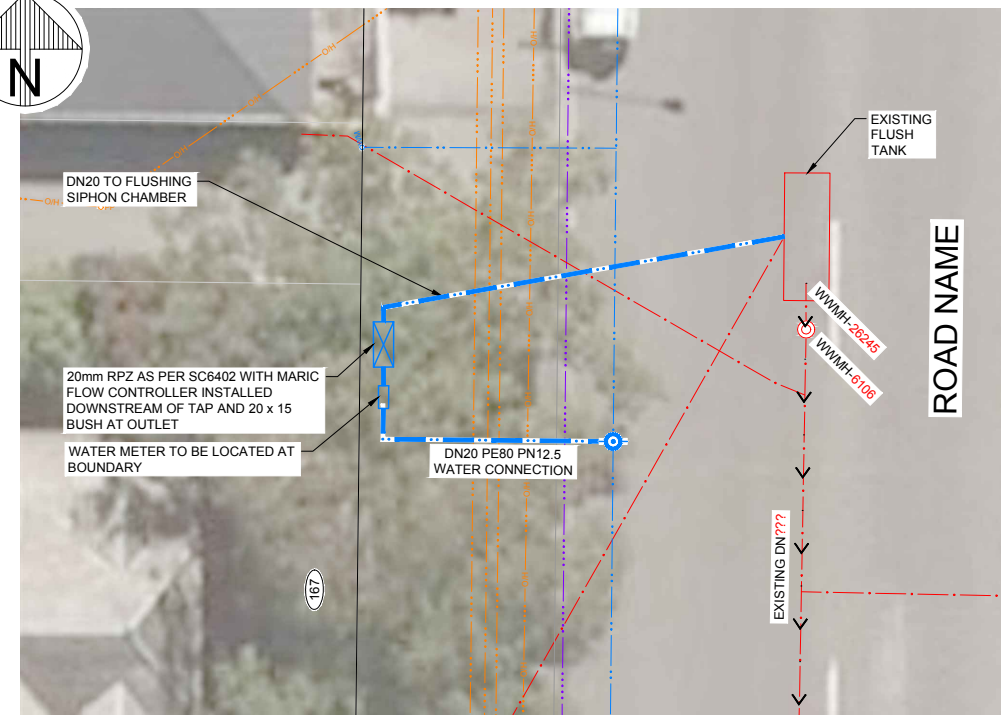
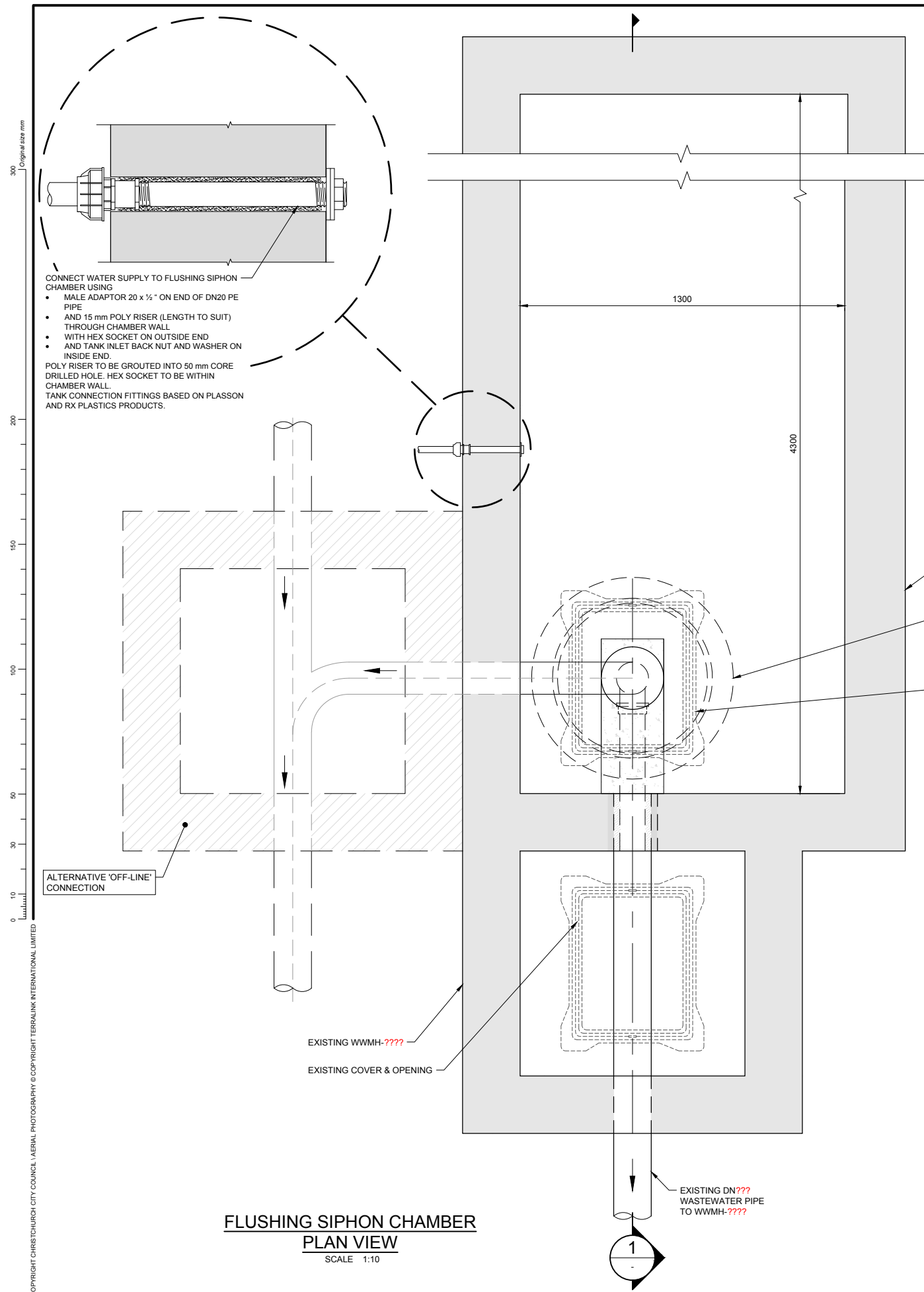

Figure 5: Steinhardt HydroFlush Device Sequence of Operation

## Appendix D Drawing Templates of Design Variations

- 10001-DE-WW-DG-WW3001 Top of Line / Off Line Flushing Siphon Chamber
- 10001-DE-WW-DG-WW3002 Inline Flushing Siphon Chamber



FLUSHING SIPHON CHAMBER (EXISTING FLUSH TANK) (SEE NOTE 3)

TWINO DN600 VENTED CARRIAGEWAY CHAMBER COVER CLASS D400 WITH DUST PAN

REMOVE EXISTING COVER

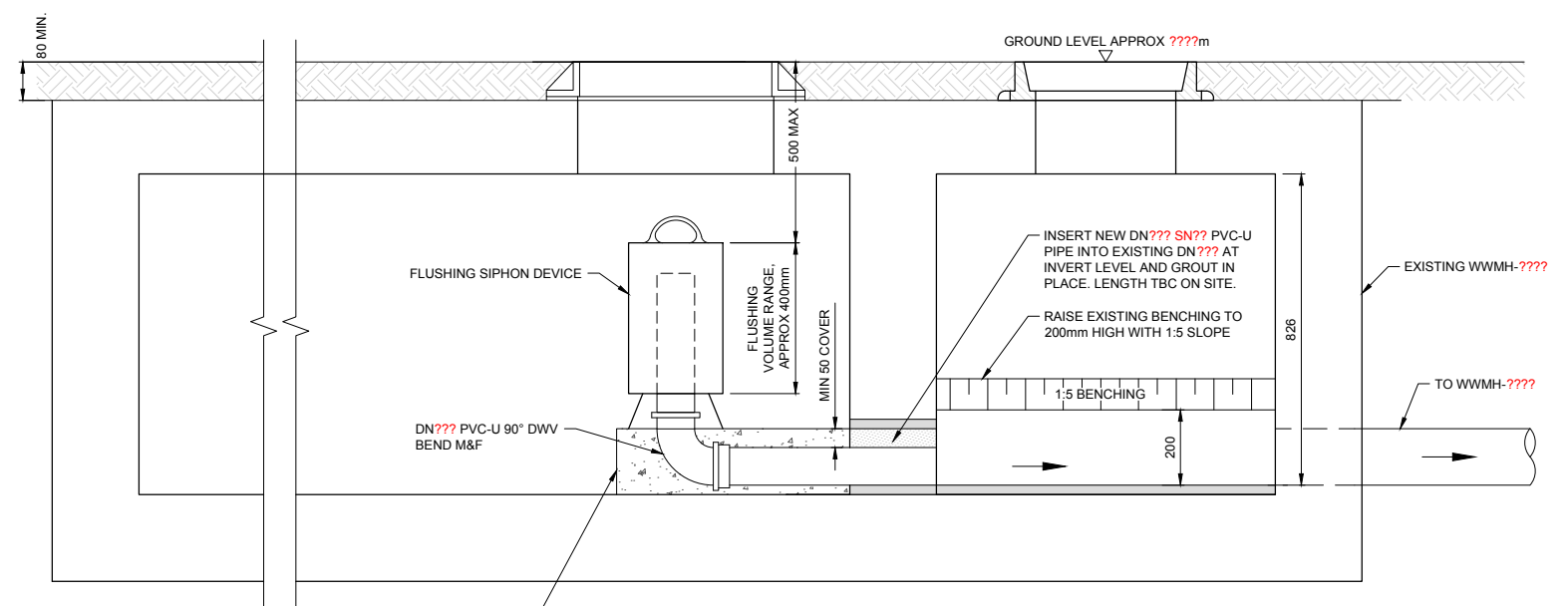

**PRELIMINARY**  
NOT FOR CONSTRUCTION



© COPYRIGHT CHRISTCHURCH CITY COUNCIL. AERIAL PHOTOGRAPHY © COPYRIGHT TERRALINK INTERNATIONAL LIMITED

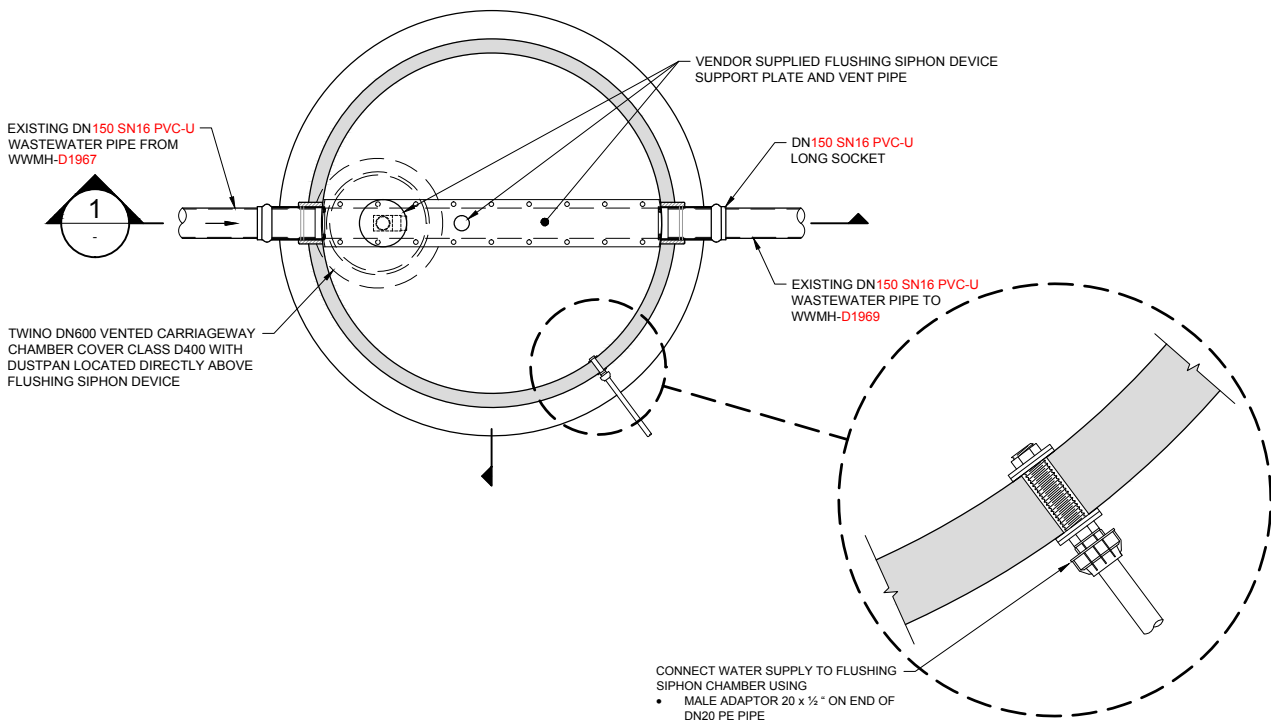

**DN1500 FLUSHING SIPHON CHAMBER**  
**PLAN VIEW**  
 SCALE NTS

CONNECT WATER SUPPLY TO FLUSHING SIPHON CHAMBER USING

- MALE ADAPTOR 20 x 1/2" ON END OF DN20 PE PIPE
- AND 15 mm TANK INLET MALE. TANK CONNECTION FITTINGS BASED ON PLASSON AND RX PLASTICS PRODUCTS.

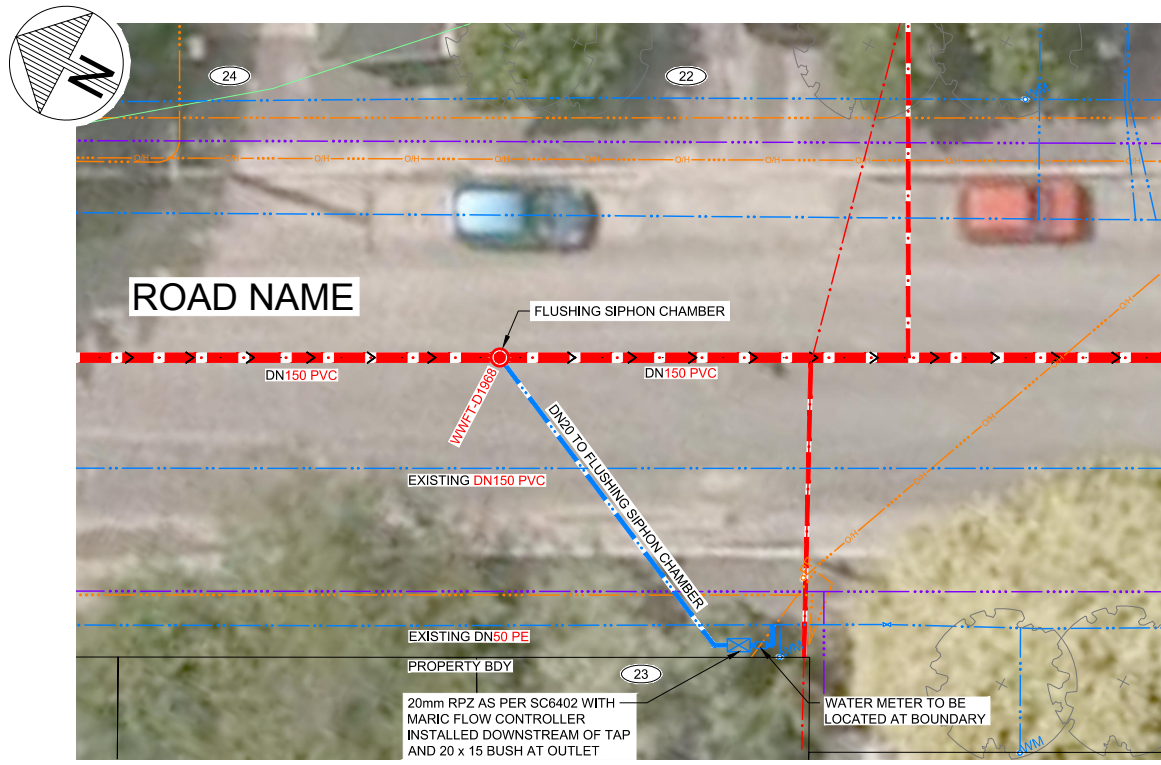

**LOCALITY PLAN**  
 SCALE 1:100

FLUSH INFORMATION	
FLUSHING SIPHON DEVICE	STEINHARDT HYDROFLUSH SH 100/250/1400
FLUSH VOLUME	2545L
FLUSH FREQUENCY	APPROX. ONCE IN 42hours @ 1.0 L/min NOMINAL FILL RATE

**LEGEND**

**EXISTING SERVICES**

- WASTEWATER
- WASTEWATER (PRESSURE)
- WASTEWATER PREV. ABANDONED
- WATER SUPPLY
- WATER SUPPLY PREV. ABANDONED
- STORMWATER
- STORMWATER PREV. ABANDONED
- POWER (& High Voltage Indicated)
- TELECOMS
- FIBRE OPTIC NETWORK
- GAS
- POWER POLE
- WATER SUPPLY VALVE
- WATER METER
- FIRE HYDRANT
- MANHOLES
- SINGLE SUMP (SS), DOUBLE SUMP (DS)

**WATERMAIN DESIGN**

- FIRE HYDRANT (FH)
- WATERMAIN
- WATERMAIN TO BE ABANDONED
- TAPPING POINT
- GATE or SLUICE VALVE FLANGED OR UNFLANGED
- THRUST BLOCK
- INLINE THRUST BLOCK
- TEE AND FLANGED TEE
- END CAP

- NOTES**
- ORGANISE WATER SUPPLY WITH CITYCARE
  - INSTRUCT CITYCARE TO INSTALL A MARIC FLOW CONTROLLER WITH THE WATER METER AS TYPICALLY USED ON CCC RESTRICTED WATER SUPPLIES. FLOW RATE 1.0 LITRES PER MINUTE
  - SEAL CONCRETE BENCHING AND PRIME STAINLESS STEEL PLATE PRIOR TO FIXING
  - BOLT SIZE AND LOCATION INDICATIVE ONLY. ACTUAL SIZE AND LOCALITY DEPENDANT ON PLATE DESIGN
  - THE SUPPORT PLATE VERTICAL SEAL ARRANGEMENT IS TO BE THE SAME AS THE HORIZONTAL ARRANGEMENT SHOWN IN DETAIL A
  - INSTALL RPZ & TOBY BOXES WITHIN 0.3m OF THE PROPERTY BOUNDARY FENCE
  - WATER SUPPLY PIPE TO HAVE A MINIMUM COVER OF 600mm.

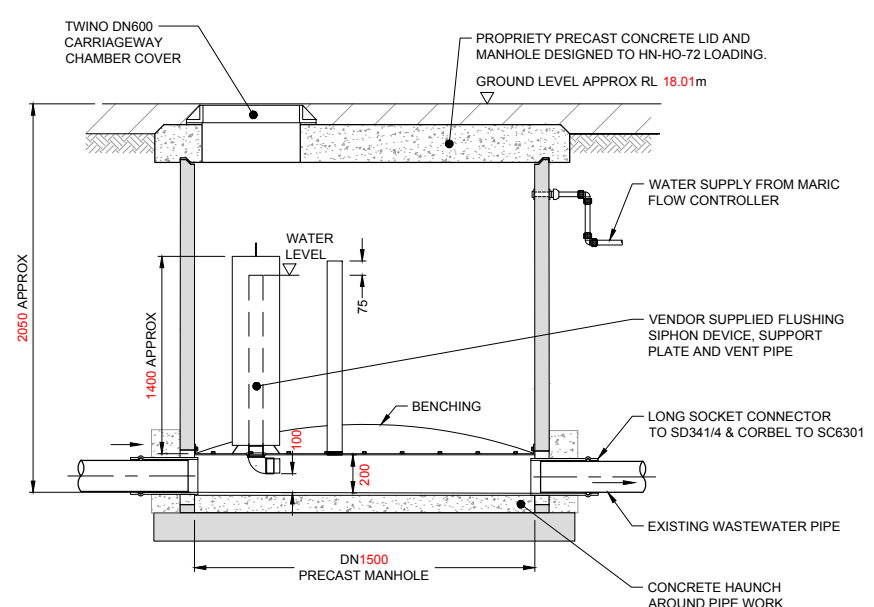

**1 SECTION**  
 SCALE NTS

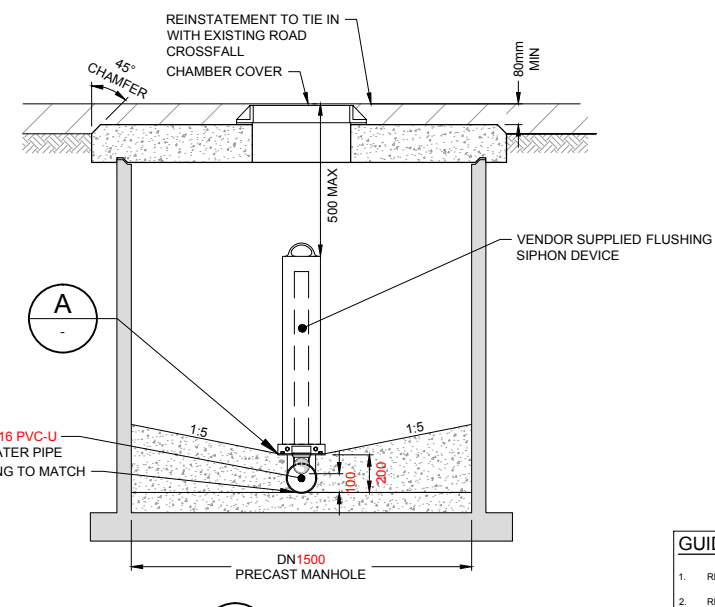

**2 SECTION**  
 SCALE NTS

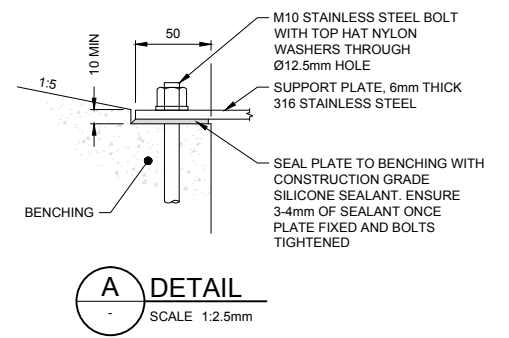

**A DETAIL**  
 SCALE 1:2.5mm

- GUIDANCE NOTES (REMOVE ONCE COMPLETED)**
- REPLACE RED TEXT ITEMS WITH PROJECT SPECIFIC DETAILS.
  - REPLACE TEMPLATE LOCALITY PLAN WITH PROJECT SPECIFIC PLAN CONTAINING THE SAME BOXES & NEW PIPE DIAMETER AS PER TEMPLATE.

**PRELIMINARY**  
 NOT FOR CONSTRUCTION

		<table border="1"> <thead> <tr> <th>NAME</th> <th>SIGNED</th> <th>DATE</th> </tr> </thead> <tbody> <tr> <td>DESIGNED</td> <td>-</td> <td>-</td> </tr> <tr> <td>DES. REVIEW</td> <td>-</td> <td>-</td> </tr> <tr> <td>DRAWN</td> <td>-</td> <td>-</td> </tr> <tr> <td>DRW. CHECK</td> <td>-</td> <td>-</td> </tr> </tbody> </table>	NAME	SIGNED	DATE	DESIGNED	-	-	DES. REVIEW	-	-	DRAWN	-	-	DRW. CHECK	-	-	<table border="1"> <thead> <tr> <th colspan="2">APPROVED</th> </tr> <tr> <th>FOR RECOMMENDATION</th> <th>DATE</th> </tr> </thead> <tbody> <tr> <td>-</td> <td>-</td> </tr> <tr> <th colspan="2">FOR CONSTRUCTION</th> </tr> <tr> <th>DATE</th> <th>SIGNED</th> </tr> <tr> <td>-</td> <td>-</td> </tr> </tbody> </table>	APPROVED		FOR RECOMMENDATION	DATE	-	-	FOR CONSTRUCTION		DATE	SIGNED	-	-		PROJECT TITLE <b>INFRASTRUCTURE REBUILD</b> <b>"CATCHMENT NAME"</b> <b>"ROAD LOCATION"</b>	DRAWING TITLE <b>INLINE FLUSHING</b> <b>SIPHON CHAMBER</b>	SCIRT PROJECT REF. <b>10001</b>	ORIGINAL SHEET SIZE <b>A1</b>	SCALES <b>AS SHOWN</b>
		NAME	SIGNED	DATE																																
DESIGNED	-	-																																		
DES. REVIEW	-	-																																		
DRAWN	-	-																																		
DRW. CHECK	-	-																																		
APPROVED																																				
FOR RECOMMENDATION	DATE																																			
-	-																																			
FOR CONSTRUCTION																																				
DATE	SIGNED																																			
-	-																																			
FILE LOCATION 10001-DE-WW-DG-3002.dwg PRINTED ON 31-Oct-16 BY locken	CONSULTANT FILE REF. <b>10001-DE-WW-DG-3002</b>	CPG CAD DRAWING FILE REF. --	CPG PROJECT FILE NUMBER --	DRAWING No. <b>WW3002</b>																																